

# MYERS® V2 GRINDER SERIES

## SHREDDING WASTEWATER CHALLENGES



**PATENT-PENDING AXIAL  
CUTTER TECHNOLOGY**



**ADVANCED HYDRAULICS**



**LEGENDARY SEAL  
LEAK DETECTION**

# MYERS® V2 SERIES SUBMERSIBLE GRINDER PUMPS

The Myers V2 series grinder is engineered from the ground up, in order to overcome the increased debris and higher pressure required in today's wastewater environment. It features a patent-pending axial cutter design and semi-open impeller to effectively macerate challenging sewage solids into a fine slurry.

Watch the video at [www.femyers.com](http://www.femyers.com)



## PATENT-PENDING AXIAL CUTTER TECHNOLOGY

Easily slices through solids and trash found in domestic wastewater without roping or clogging.



## ADVANCED HYDRAULICS

The only single stage 2 HP grinder that can deliver up to 180' of lift for superior performance and reliability.

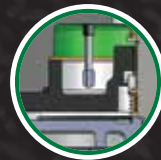

## LEGENDARY SEAL LEAK DETECTION

True early warning system for reduced downtime and maintenance costs.

# FEATURES

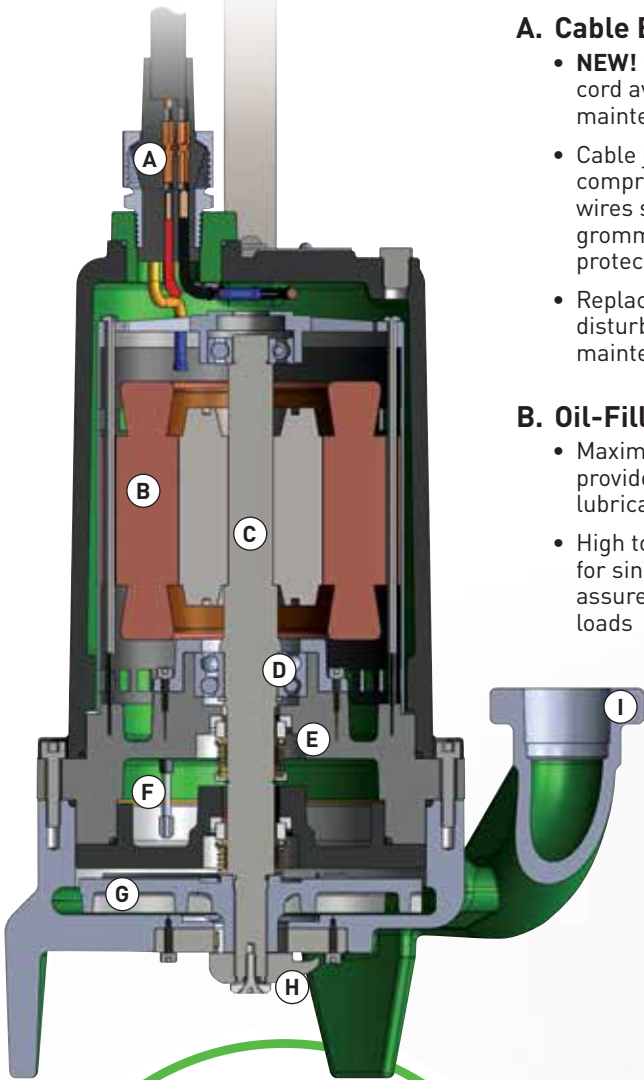

## A. Cable Entry System

- **NEW!** Optional quick disconnect cord available for ease of maintenance
- Cable jacket sealed by compression fitting; individual wires sealed by compression grommet for double seal protection against water ingress
- Replace power cord without disturbing motor for ease of maintenance

## B. Oil-Filled Motor

- Maximizes heat dissipation; provides constant bearing lubrication for long life
- High torque start/run capacitor for single or three-phase motors, assured starting under heavy loads

## C. Heavy 416 SST Shaft

- Corrosion resistant, reduces shaft deflection for long life

## D. Lower Double Row Ball Bearings

- Absorb both axial and radial loads for increased durability

## E. Double Mechanical Shaft Seals

- In oil-filled seal chamber for continuous lubrication, superior motor protection

## F. Seal Leak Probe

- Located in seal chamber instead of motor area for true early warning of water leaks. Allows corrective action before costly motor or bearing failure occurs.
- Activates warning light in control panel

## G. SST Semi-Open Impeller

- Provides improved performance, resists clogging
- Pump-out vanes help keep trash from seal, reduces pressure at seal face for longer life

## H. Axial Cutter System

- Constructed of 440 SST hardened to 57-60Rc for long life
- Easily replaceable without dismantling pump

## I. Volute Case

- Cast iron 1-1/4" NPT vertical flanged discharge

## CUTTING SYSTEM

Easily switch between standard and high head flows by simply changing the impeller and cutter plate.

HIGH HEAD CUTTING PLATE

STANDARD CUTTING PLATE





# PERFORMANCE DATA AND DIMENSIONS

3450 RPM

[Dimensions in mm]

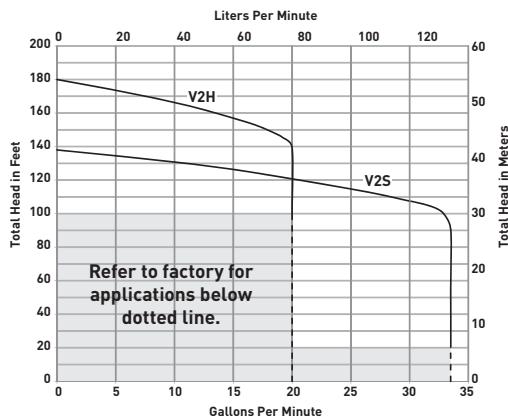
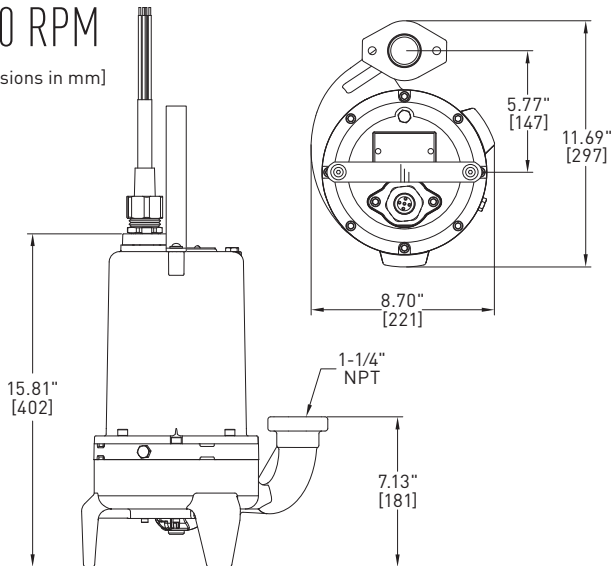

## Product Capabilities

Capacities To	34 gpm	129 lpm
Heads To	180 ft.	54.86 m
Liquids Handling	domestic raw sewage	
Intermittent Liquid Temp.	up to 140°F	up to 60°C
Winding Insulation Temp. (Class F)	311°F	155°C
Motor Electrical Data <small>(Single phase motors are capacitor start type. Myers control panels or capacitor kits are recommended for proper operation and warranty.)</small>	2 hp, 3450 rpm 1 ph – capacitor start/run. 230 volts; 60 Hz 3 ph – induction run 200, 230, 460 volts, 60 Hz	
Std. Third Party Approvals	CSA	
Acceptable pH Range	6 – 9	
Specific Gravity	.9 – 1.1	
Viscosity	28 – 35 SSU	
Discharge (Flange Dia.)	1-1/4 in.	31.75 mm
Min. Sump Diameter		
Simplex	24 in.	61.0 cm
Duplex	36 in.	91.4 cm

## Construction Materials

Motor Housing, Seal Housing, Cord Cap and Volute Case	Cast Iron, Class 30, ASTM A48
Impeller	Semi-Open, Stainless Steel
Power Cord	20' S00W
Mechanical Seals: Standard Optional	Double Tandem Carbon and Ceramic Lower Tungsten Carbide
Pump, Motor Shaft	416 SST
Fasteners	300 Series SST
Rotating Cutter, Stationary Cutter	440 SST 57-60 Rockwell

	V/Ph/Hz	HP	Start Amps	FL Amps	Full Load kW	Start KVA	FL KVA	NEC Code Letter	Service Factor	Model	Standard Cord		Quick Disconnect		
											20'	35'	20'	35'	50'
High Head	230/1/60	2	49	18.5	4.2	11.27	4.26	G	1	Catalog Eng	VH20-21-20 28148D000	VH20-21-35 28148D004	VH20-21-20Q 28148D008	VH20-21-35Q 28148D009	VH20-21-50Q 28148D010
	200/3/60	2	53	12.5	3.9	18.3	4.33	L	1	Catalog Eng	VH20-03-20 28148D001	VH20-03-35 28148D005	VH20-03-20Q 28148D011	VH20-03-35Q 28148D012	VH20-03-50Q 28148D013
	230/3/60	2	46	12	3.9	18.3	4.77	L	1	Catalog Eng	VH20-23-20 28148D002	VH20-23-35 28148D006	VH20-23-20Q 28148D014	VH20-23-35Q 28148D015	VH20-23-50Q 28148D016
	460/3/60	2	23	6	3.9	18.3	4.77	L	1	Catalog Eng	VH20-43-20 28148D003	VH20-43-35 28148D007	VH20-43-20Q 28148D017	VH20-43-35Q 28148D018	VH20-43-50Q 28148D019
Standard Flow	230/1/60	2	49	18.5	4.2	11.27	4.26	G	1	Catalog Eng	VS20-21-20 28151D000	VS20-21-35 28151D004	VS20-21-20Q 28151D008	VS20-21-35Q 28151D009	VS20-21-50Q 28151D010
	200/3/60	2	53	12.5	3.9	18.3	4.33	L	1	Catalog Eng	VS20-03-20 28151D001	VS20-03-35 28151D005	VS20-03-20Q 28151D011	VS20-03-35Q 28151D012	VS20-03-50Q 28151D013
	230/3/60	2	46	12	3.9	18.3	4.77	L	1	Catalog Eng	VS20-23-20 28151D002	VS20-23-35 28151D006	VS20-23-20Q 28151D014	VS20-23-35Q 28151D015	VS20-23-50Q 28151D016
	460/3/60	2	23	6	3.9	18.3	4.77	L	1	Catalog Eng	VS20-43-20 28151D003	VS20-43-35 28151D007	VS20-43-20Q 28151D017	VS20-43-35Q 28151D018	VS20-43-50Q 28151D019



1101 MYERS PARKWAY, ASHLAND, OH 44805 WWW.FEMYERS.COM  
PH: 419-289-1144

Because we are continuously improving our products and services, Pentair reserves the right to change specifications without prior notice.