

MODEL 411



MODEL 413

AURORA[®] 410 SERIES SINGLE STAGE SPLIT CASE PUMPS

AURORA® 410 SERIES

Single Stage Split Case Pumps

Capacities to 15000 GPM (3407 m³/hr)

Heads to 663 Ft. (202 m)

Temperatures to 275°F (135°C)

Introduction

The horizontal split case pump has long been used for the handling of liquids where the utmost in reliability and accessibility is paramount. Billions of gallons of liquid have been pumped by split case double suction pumps and billions more will be pumped considering the rapid industrial, agricultural and commercial expansion. The Aurora 410 Series pumps make a significant contribution to the customer requirements for pumps on this type of service. The 410 Series is a modern design based on Aurora's over 90 years of experience with the design, sales and manufacturing of split case pumps. Look through this brochure and see what real accomplishments can be made when an imaginative approach is taken to the customer's problem of moving liquids within a piping system.

Model 411 is horizontally baseplate mounted with a driver flexibly coupled to the pump. This design is recommended where floor space is readily available and where flooding of the installation is not possible.

Model 412 is vertically mounted and uses flexible shafting between the driver and the pump. This model is frequently used on difficult applications where flooding of the installation is a possibility.

Model 413 is vertically mounted with an elevated driver coupled directly to the pump through a flexible coupling. Model 413 is very popular for installations where available floor space is limited and where possible flooding is marginal.

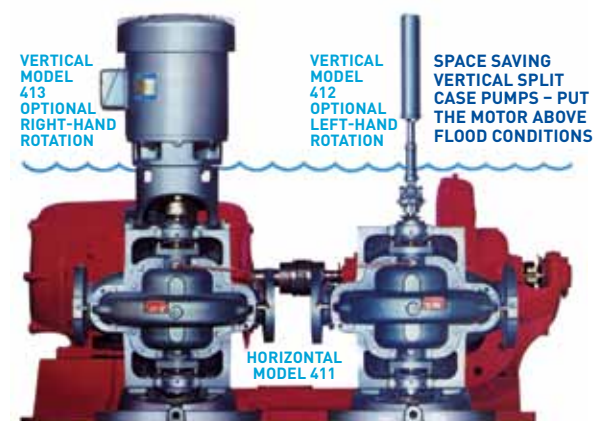

Pump Features

Standard Features

- Bronze fitted pump construction
- Bronze shaft sleeves
- Dynamically balanced impellers
- Bronze case wearing rings
- Twin volute on 10" and larger pumps
- Stainless steel impeller key
- Regreaseable ball bearings
- Single row ball bearing (inboard)
- Double row ball bearing (outboard)
- Mechanical seals...single unbalanced (Models 412 and 413)
- Graphite and TFE lubricated acrylic packing

- Internal bypass between casing and stuffing box
- 125# ASA flanges
- 250 psi case working pressure
- Carbon steel shaft
- Stuffing box bushings
- Lifting lugs
- Hydrostatic test
- Cast integral bearing arms
- Water slingers and grease seals
- External bypass between casing and stuffing box (Models 412 and 413)
- Coupling guard (Model 411)

Optional Features

- All iron, all bronze or special alloy pump construction
- Hardened 440C stainless steel shaft sleeves (packing only)
- 316 stainless steel shaft sleeves (mechanical seal)
- Impeller wearing rings
- Oil lubricated ball bearings (Model 411 horizontal pump)
- Mechanical seals
 - single unbalanced (Model 411)
 - single balanced (all models)
- Stainless steel or Monel® shaft
- External bypass between casing and stuffing box (Model 411)
- Steel drip rim, formed steel or fabricated steel bases
- Double extended shaft (Model 411)
- Right- or left-hand rotation
- Certified performance test
- Packing with lantern ring (Model 411)
- 250# ASA suction and discharge flanges
- Bottom suction or chairmounted pumps
- Water cooled cartridge caps

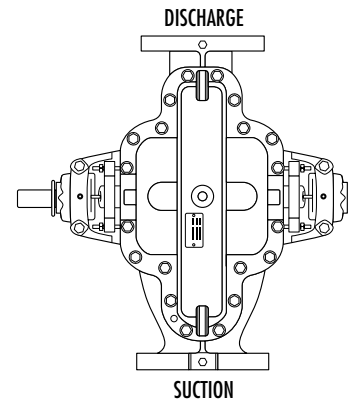

**STANDARD
RIGHT HAND ROTATION**

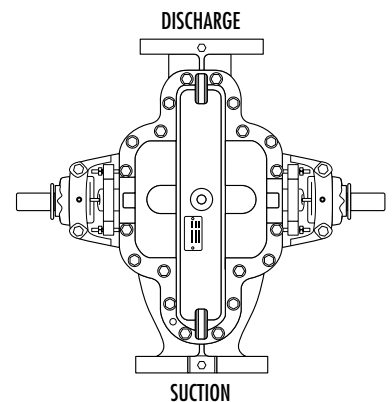

**OPTIONAL DUAL DRIVE
RIGHT HAND ROTATION**

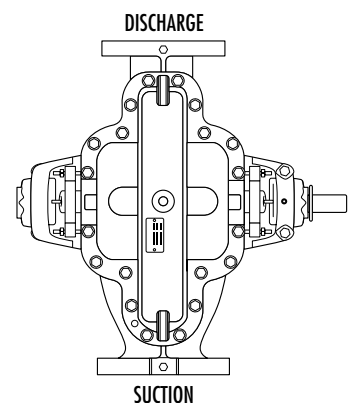

**OPTIONAL
LEFTHAND ROTATION**

Horizontal Pump Features

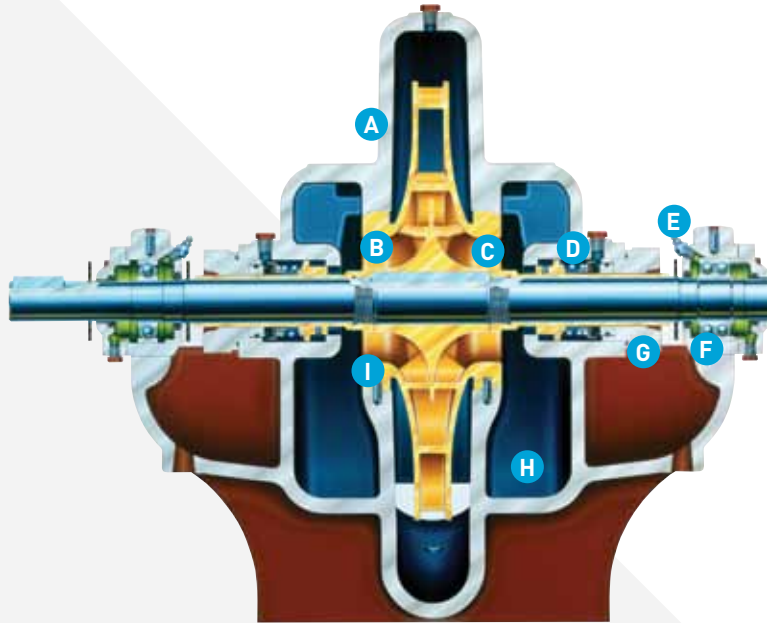

A. Split Case Design

simplifies disassembly. The suction and discharge piping and alignment is not disturbed. Simply remove the upper casing for service or inspection. Cast lifting lugs are provided. Computer-machined major components with 360 degree registered fits assure concentricity of all parts. Twin volute design balances out radial hydraulic thrust loads on larger split case pumps (see Range Charts).

B. Dynamically Balanced Impeller

is keyed to the shaft and secured by adjustable shaft sleeves. Double suction design balances out hydraulic thrust loads. Vacuum cast process and proven design provides high efficiency and performance.

C. Bronze Shaft Sleeve

prevents shaft wear, is slip fit over the shaft, keylocked and extends the entire length of each stuffing box. Shaft sleeves and impeller are O-ring sealed to eliminate corrosion of the shaft by the pumped liquid. This eliminates the need for high cost, special stainless steel or Monel® shafts.

D. Interchangeable Stuffing Box

for mechanical seals or packing. Packing is standard on horizontal pumps. Optional lantern rings have internal water seal passages between the casing and stuffing box and cannot be damaged. Mechanical seals have carbon against ceramic face. Long life is assured with 303 stainless steel metal parts and Buna-N elastomers. Several optional mechanical seals are available.

E. Grease Lubrication

purges old grease from bearing. Oil lubrication is optional on horizontal pumps. Lube fittings are conveniently located for quick access and provide positive bearing lubrication. Oil seals and nonsparking neoprene rotating slingers protect both bearings during pump operation and washdowns.

F. Bearings

selected for 50,000 hour minimum life at maximum load. Average bearing life 5 x minimum. Double row thrust ball bearing is standard on all models. Short bearing span holds shaft deflection to .002" at face of stuffing box at maximum load. Integral bearing arms eliminate bearing misalignment and simplify service.

G. Left-Hand Rotation

can be readily provided with standard parts. Tandem drive pumps require only a different shaft.

H. Certified Performance

with positive suction pressure or with a suction lift is available on each pump for customer approval. Pumps are all hydrostatically tested.

I. Case Wearing Rings

and throttle bushings prevent wear on the pump casing and are easily and inexpensively replaced.

Vertical Pump Features

Key Features

A. Coupling Alignment

with true alignment is vital to long life and proper performance. To maintain proper coupling alignment, the mounting bracket is rabbet fitted to the motor.

B. Mechanical Seals

Standard construction includes carbon against ceramic face for optimum hot water performance. Long life is also assured with 303 stainless steel metal parts and Buna-N elastomers.

C. Bearing Protection

Grease seals and water slingers are provided to protect the bearings from contamination. This important feature is also standard on horizontal pumps.

D. Cast Iron Drip Rim Base

Accurate positioning of the pump is assured by the mounting base. A drip rim is incorporated in the base design to control condensation and leakage.

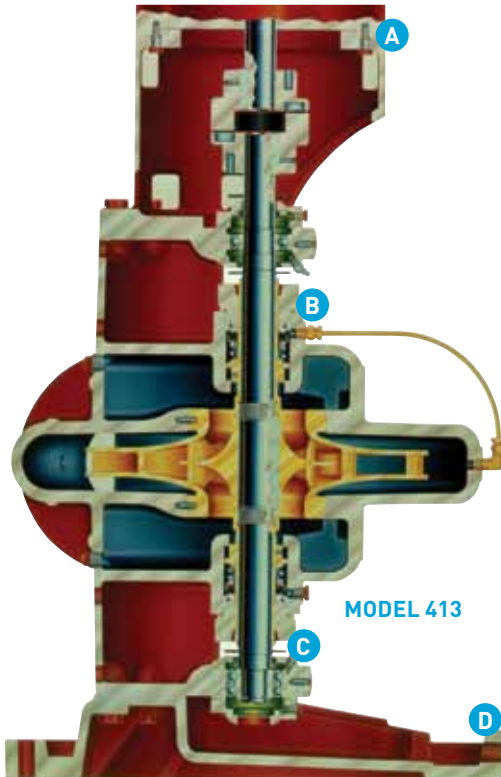

Benefits

Go vertical and put two pumps where only one horizontal would fit.

Aurora's® space saving vertical split case pumps have long been recognized for their reliability. This reputation in the field of vertical installations has been re-emphasized since the introduction of the Model 413 as pumps of unmatched quality.

Vertical pumps provide distinct advantages over horizontal pump construction.

- Less floor space required.
- Inline piping arrangement allows piping in any direction.
- Elevated motor protects against potential flooding if the pump station is in a low area. Additional features described for the horizontal pumps are also found in the vertical pumps. There are several features unique only to Model 413.

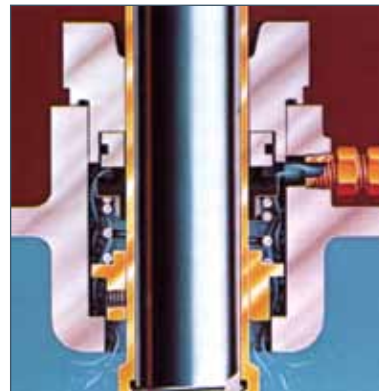

EXTERNAL UPPER SEAL FLUSH

Range Charts

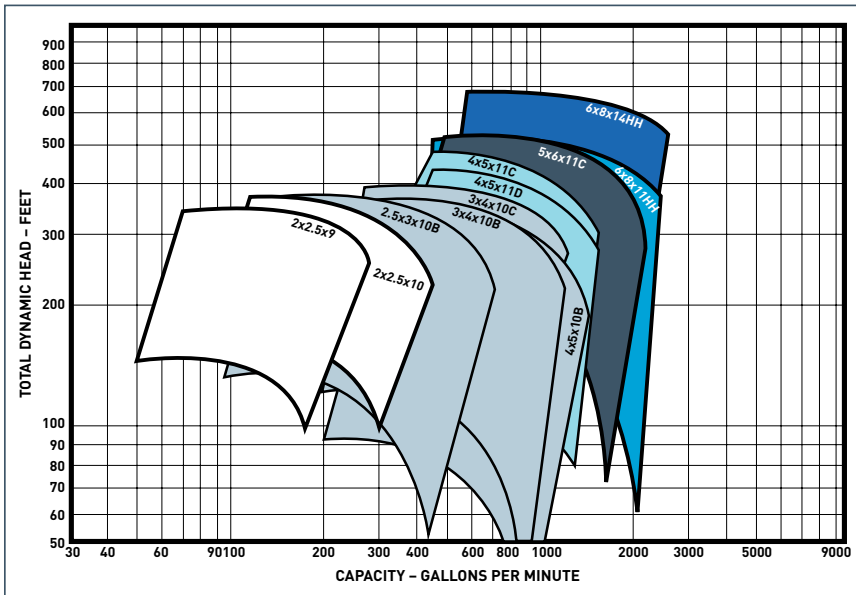

Single Volute 3500 RPM

Individual performance curves should be checked for final selection. For selections not shown on this chart, please refer to the factory.

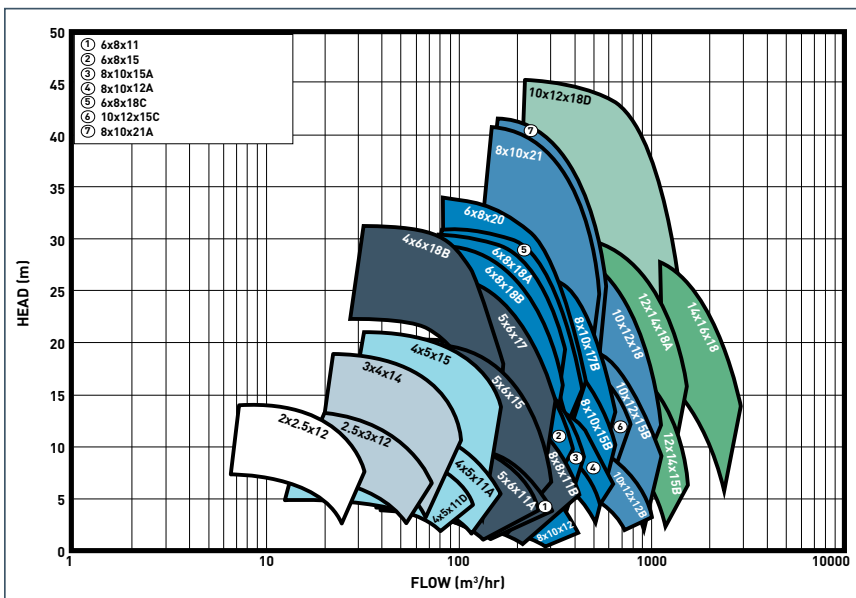
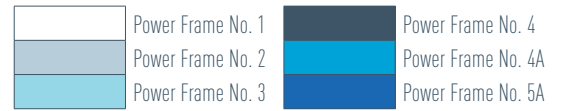

1000 RPM

Individual performance curves should be checked for final selection. For selections not shown on this chart, please refer to the factory.

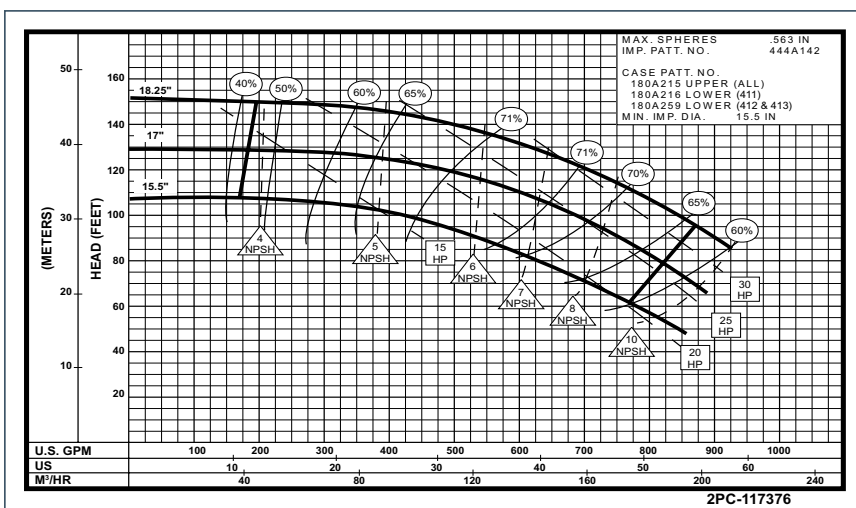
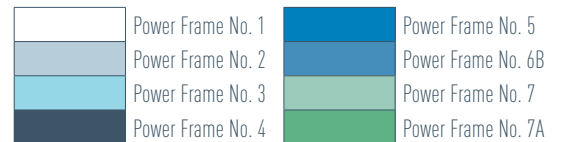

Performance Curves

The individual curve for the size pump selected is found in the catalog. These performance curves give complete operating characteristics, efficiency, horsepower and N.P.S.H. required. Horsepower lines on these curves are based on specific gravity of 1.0. To obtain the horsepower for a liquid of a different specific gravity, multiply the horsepower obtained from the curves by the specific gravity of that liquid. The performance curve illustrated to the left is typical of the individual curves readily available for each pump size.

Range Charts

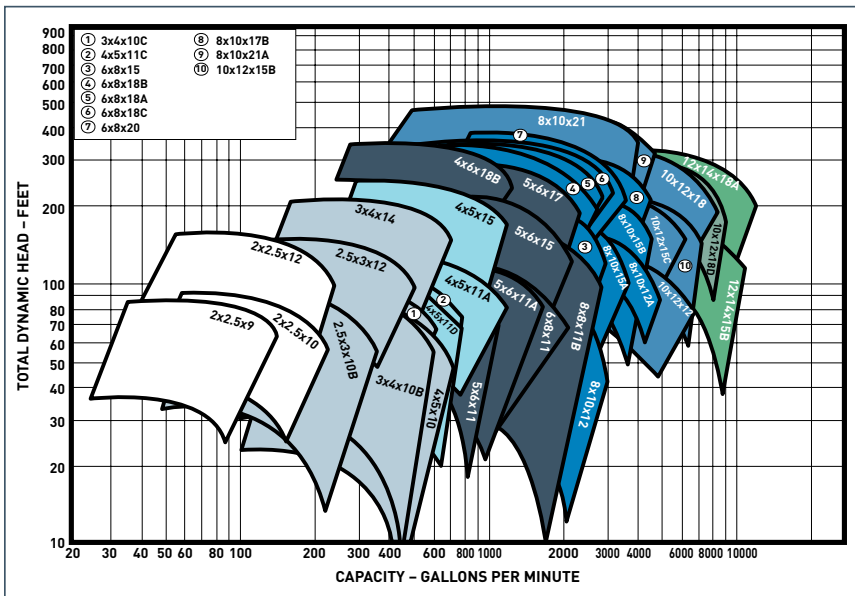
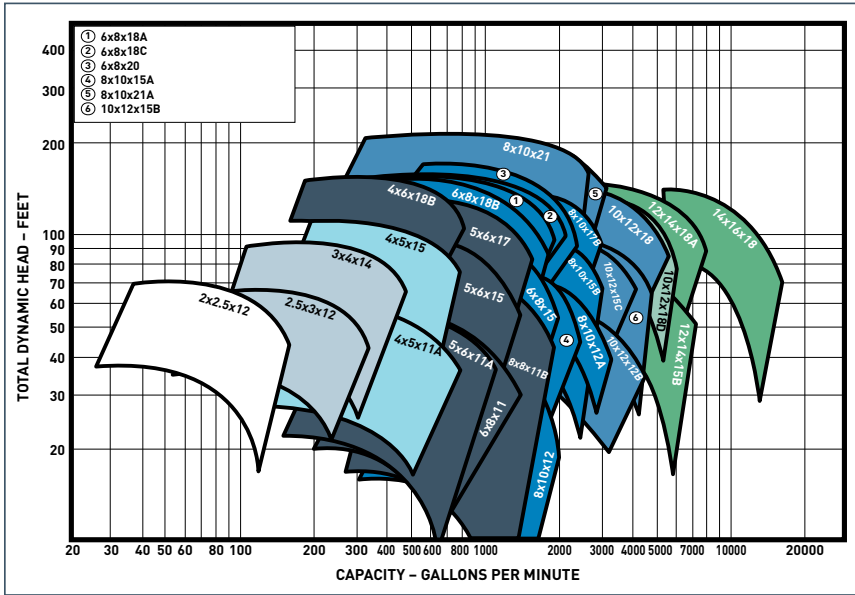

Range Charts

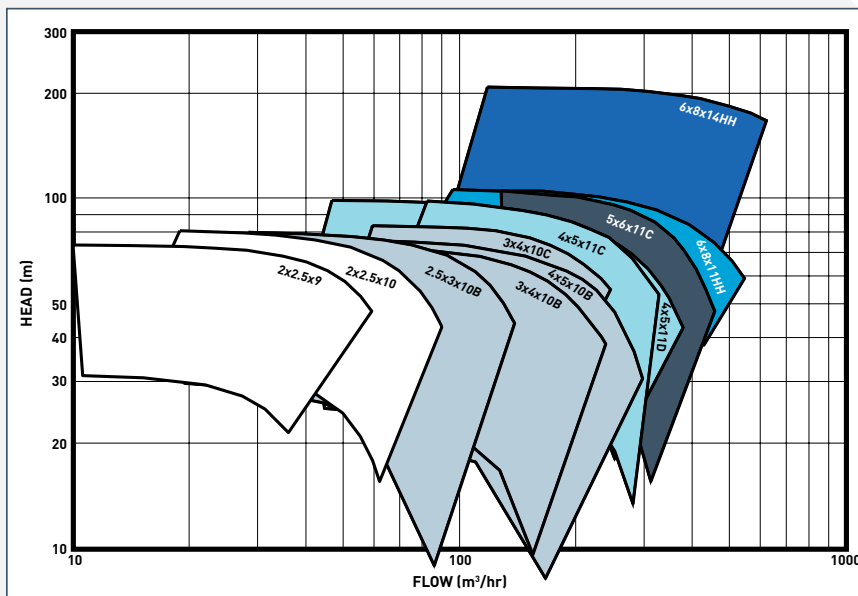
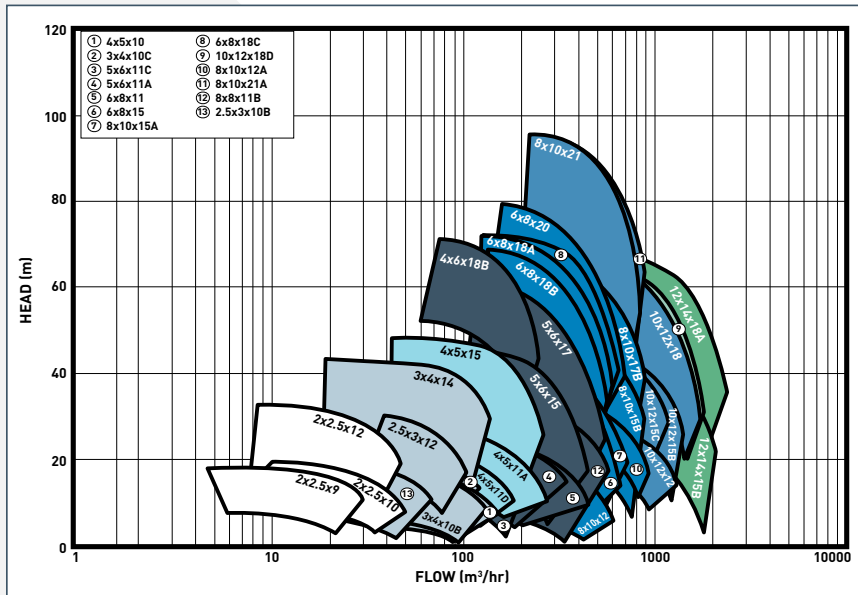

Pump Dimensions

Pump Size	Disch.	Suction	Bore	Pwr. Series	Pump Wgt. (lbs.)		A	D**	S	X	CP	HY	VE	YY	
					411	413									
2x2.5x9	2	2-1/2	9	1	145	215	18	7	3-1/2	8-1/2	21	4-1/2	11-1/8	9	
2x2.5x10	2	2-1/2	10		145	215	18	7	3-1/2	8-1/2	21	4-1/2	11-1/8	9	
2x2.5x12	2	2-1/2	12		175	260	18	8	4	10	21	4-1/2	11-1/8	10-3/4	
2.5x3x10	2-1/2	3	10	2	215	300	18	8	4	9-3/4	24	5-1/2	13	10	
2.5x3x12	2-1/2	3	12		255	360	18	9	4-1/2	11	24	5-1/2	13	11-1/2	
3x4x10	3	4	10		260	365	18	9	4-1/2	10	24	5-1/2	13	11	
3x4x14	3	4	14	3	310	435	18	10	5	12	24	5-1/2	13	13	
4x5x10	4	5	10		330	465	18	9	4-5/8	10	24	5-1/2	13	11-1/4	
4x5x11	4	5	11		390	435	22	10	5	11-1/4	26	6-1/2	14	12-3/4	
4x5x15	4	5	15	4	415	490	22	11	5-1/2	13	26	6-1/2	14	14	
4x6x18	4	6	18		560	780	22	12-1/2	6-1/4	14	29	6-1/2	15	16	
5x6x11	5	6	11		455	580	22	11	5-1/2	11-1/4	29	6-1/2	15	13-1/4	
5x6x15	5	6	15	5	530	735	22	12-1/2	6-1/4	13-1/4	29	6-1/2	15	15	
5x6x17	5	6	17		635	855	22	12-1/2	6-1/4	14	29	6-1/2	15	15	
6x8x11	6	8	11		520	650	22	12-1/2	6-1/4	11-3/4	29	6-1/2	15	14-1/2	
8x8x11	8	8	11	6B	605	835	22	12-1/2	6-1/4	12	29	6-1/2	15	14-1/2	
6x8x11HH	6	8	11HH		4A	990	1095	22	13-3/16	8-5/8	10	32-3/4	8-1/2	17-1/8	15
6x8x14HH	6	8	14HH		5A	1190	1410	30	13-3/16	7-1/2	15	36-3/4	8-1/2	19-7/16	17
6x8x15	6	8	15	5	585	735	30	13-1/2	6-3/4	14-1/4	32	7-1/2	17	16-3/4	
6x8x18	6	8	18		800	1020	30	14-3/4	8	16	32	7-1/2	17	18	
6x8x20	6	8	20		875	1095	30	14-3/4	8	15-3/4	32	7-1/2	17	18	
8x10x12	8	10	12		740	925	30	14-3/4	8*	17	32	7-1/2	17	17-3/4	
8x10x15	8	10	15		835	1040	30	14-3/4	8*	17	32	7-1/2	17	17-3/4	
8x10x17	8	10	17		865	1085	30	14-3/4	8	17	32	7-1/2	17	17-3/4	
8x10x21	8	10	21	7A	955	++	++	18-1/2	9-1/2	18	38	11-1/2	-	21	
10x12x12	10	12	12		1325	1575	40	23	12	16	38	11-1/2	-	19	
10x12x15	10	12	15		1390	++	++	25	13-1/2	17	38	11-1/2	-	20	
10x12x18	10	12	18	7	1725	++	++	25	13-1/2	18	38	11-1/2	-	22	
10x12x18D	10	12	18D		1920	++	++	25	12-1/4	20	42-15/16	11-1/2	-	24	
12x14x15	12	14	15		2000	++	++	24	15	17	44	11-1/2	-	22	
12x14x18	12	14	18	7	2100	++	++	24	15	18	44	-	-	23	
14x16x18	14	16	18		2850	++	++	29-1/4	16	22	44	-	-	27	

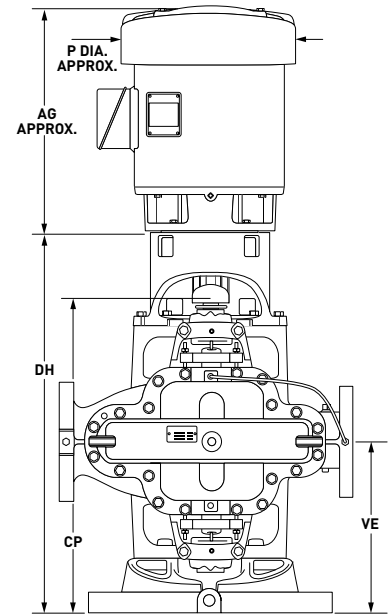

MODELS 412 AND 413

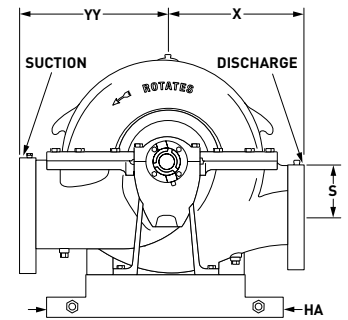

MODEL 411

Models 412 and 413

Pwr. Series		1	2	3	4	5
DH	Up to 256 hp	26	30	33	35	-
	284 hph and up	28	32	35	37	41
CP		23	27	29	31	35

Notes - Apply to all models:

* Add 1" for true discharge centerline.

** Always use largest of 2 "D" dimensions.

†† These pump sizes are available in a vertical chair mount configuration in Models 412 and 413. See individual dimensions pages for complete dimensions and weights.

Engineering Specifications

Models 411, 412 and 413 Split Case Base Mounted

Furnish and install as shown on the plans ____ Right-hand (Left-hand) Aurora® Model (Horizontal – 411) (Vertical – 412 Open Shaft) (Vertical – 413 Flexible Coupled) type Split Case, Double Suction, Single Stage centrifugal pump, size ____x____x____ of bronze fitted (all bronze) (all iron) (stainless steel) construction. The pump shall be capable of delivering at design conditions a capacity of ____ GPM when operating against a Total Dynamic Head of ____ feet, with a temperature of ____ °F, specific gravity _____. Pump shall have minimum guaranteed efficiency at design capacity of ____%. Pump must also be capable of delivering a maximum of ____ GPM when operating against a head of ____ feet, and at this condition shall have a minimum efficiency of ____%. Minimum shut-off head acceptable will be ____ feet. Pump shall operate at a maximum synchronous speed of ____ RPM.

A unit operating at a lesser rotative speed will be considered, but in no event will a pump operating at more than the maximum speed specified be acceptable. The pump casing halves shall be of the inline piping design and will be constructed of Class 30 cast iron having a minimum tensile strength of 30,000 psi and shall be of sufficient thickness to withstand stresses and strains at full operating pressures.

Casings shall be subject to a hydrostatic pressure test at 150% of the specified duty point. Bearing housing supports, suction and discharge flanges shall be integrally cast with the lower half of the casing. Removal of the upper half of the casing must allow the rotating element to be removed without disconnecting the suction and discharge flanges. The upper casing is to be dowel aligned to the lower casing.

Pump sizes 10" and larger are to be of the twin volute design. Drain openings must be provided in the bearing arms for removal of

lubricating liquid. Impeller shall be of the enclosed double suction type and shall be vacuum cast bronze (____). Impeller shall be dynamically balanced and securely fastened to the shaft by key and screw locked shaft sleeves. The vanes shall be designed to reduce noise. The pump shaft shall be made of high grade SAE 1045 steel or equal, accurately machined to give a true running rotating element. The minimum dia. acceptable will be ____". The shaft shall be protected from wear by bronze (____) sleeves which are key locked and threaded so that the sleeves tighten with the rotation of the shaft. Buna O-rings must be provided between the impeller hub and the shaft sleeves to prevent pumped liquid from corroding the shaft.

Pump shall be equipped with easily renewable bronze (____) casing rings (impeller wearing rings) so designed that hydraulic pressure will seat them against a shoulder in the pump case around the full periphery of the wearing ring. The wear rings will be locked in place by the doweling to prevent rotation. The rotating element shall be mounted in heavy duty grease lubricated ball bearings and shall be equipped with water strainers on side next to pump glands.

Bearing housings shall be so designed to flush lubricant through and provide continuous cleaning of bearing surfaces and maximum protection against overheating. The pump shall be supplied with a single row inboard bearing primarily for radial loads and double row outboard bearing primarily for thrust loads. Both bearings shall be regreaseable lubrication ball type, designed for 250,000 hours average life. Each bearing shall be mounted in a machined housing that is moisture- and dust-proof. The housing shall have registered fits to assure alignment, pinned to prevent rotation and bolted to the bearing arms. Each housing shall be supplied with a grease fitting and a plugged relief port.

Engineering Specifications

Model 411

Stuffing boxes shall be placed on both sides of the pump centerline to seal the pump shaft. All packed pumps having a suction lift shall be provided with lantern rings connected to the pressure side of the pump by cored passages in the parting flange of the pump. The stuffing boxes shall be equipped with heavy, cast, split glands with extra length, for easy removal for packing inspection and maintenance. Pump and motor shall be mounted on a common heavy baseplate of (steel with drip rim) (formed steel) (structural steel). Pump and motor must be checked for alignment after the pump base has been installed and grouted in place, in accordance with the standards of the Hydraulic Institute. There shall be no strain transmitted to the pumps.

Models 412 and 413

Mechanical seal boxes shall be placed on both sides of the pump centerline to seal the pump shaft. Each pump is to be furnished with mechanical seals with all metal parts to be 303 stainless steel with Buna-N elastomers, ceramic seat, and carbon washer. A bypass line must be provided for the upper seal between the seal faces and the discharge flange to assure adequate venting of the seal chamber and to provide lubrication. All pumps shall be provided with cored passages in the parting flange of the pump to provide additional circulation to both seals. The mechanical seal boxes shall be equipped with heavy, cast, one piece O-ring sealed glands. The pump shall be supported by a cast iron drip rim base.

Model 412

Vertical open shaft pumps are to be driven through flexible shafting with dia. tubing and intermediate bearings. Shafting must be of sufficient size to transmit required HP and must be provided with a slip spline which will permit removal of the pump rotating assembly without removing any section of intermediate shafting, bearings, suction or discharge piping.

Model 413

Vertical flexible coupled pumps shall be furnished with a cast iron motor bracket which is to be bolted to the vertical casing. The motor bracket must be machined with a register fit to ensure proper alignment of motor and pump shaft.

Models 411 and 413

The pumps shall be flexible coupled to a standard (horizontal) (vertical) NEMA, ____ HP, ____ phase, ____ Hertz, ____ volts, ____ RPM (drip-proof) (tot. encl.) (hazardous location) motor.



800 AIRPORT ROAD, NORTH AURORA, ILLINOIS 60542 WWW.AURORAPUMP.COM

Monel is a registered trademark of Special Metals Corporation.

Aurora is a registered trademark of Pentair Ltd.

Because we are continuously improving our products and services, Pentair reserves the right to change specifications without prior notice.

A-02-1017 1/2/13 © 2013 Pentair Ltd. All Rights Reserved.